

INSTALLATION GUIDE



DP Series - ALUMINUM DEDICATED HORIZONTAL PLENUM COILS WITH AUXILIARY DRAIN PAN

Contents

1. Safety Instructions & Warning Labels
2. Inspection
3. Installation Preparation
4. Condensate Drain Preparation
5. Coil Installation
 - 5A. Dedicated Horizontal Plenum Drain Port Location
 - 5B. Dedicated Horizontal Plenum Orientation
 - 5C. Mounting Dedicated Horizontal Plenum To Furnace
 - 5D. Mounting Auxiliary Pan
 - 5E. Duct Attachment
6. Refrigerant Line Connection
7. Metering Devices/Liquid Line Connection
 - 7A. Piston Coils
 - 7B. TXV Coils
8. Leak Check
9. System Charging
10. Coil Cleaning Instructions

1. Safety Instruction



Read the precautions in this manual carefully before operating the unit.

Potential safety hazards are alerted using the following symbols. The symbol is used in conjunction with terms that indicate the intensity of the hazard.

WARNING

This symbol indicates a potentially hazardous situation, which if not avoided, could result in serious injury, property damage, product damage or death.

CAUTION

This symbol indicates a potentially hazardous situation, which if not avoided, may result in moderate injury or property damage.

WARNING

Product designed and manufactured to permit installation in accordance with local and national building codes. It is the installer's responsibility to ensure that the product is installed in strict compliance with the aforementioned codes. Manufacturer assumes no responsibility for damage (personal, product or property) caused due to installations violating regulations.

WARNING

Certified technicians or those individuals meeting the requirements specified by NATE may use this information. Property and product damage or personal injury hazard may occur without such background.

WARNING

This appliance is not intended for use by persons (including children) with reduced physical, sensory, or mental capabilities, or lack of experience and knowledge, unless they have been given supervision or instruction concerning use of the appliance by a person responsible for their safety. Children must be supervised to ensure that they do not play with the appliance.

2. Inspection

On receiving the product, visually inspect it for any major shipping related damages. Shipping damages are the carrier's responsibility. Inspect the product labels to verify the model number and options are in accordance with your order. The manufacturer will not accept damage claims for incorrectly shipped product.

3. Installation Preparation

Read all the instructions in this guideline carefully while paying special attention to the WARNING and CAUTION alerts. If any of the instructions are unclear, clarify with a certified technician before proceeding. Gather all tools needed for successful installation of the unit prior to beginning the installation. Check coils for leaks prior to installation.

4. Condensate Drain Preparation

Aspen recommends an auxiliary drain pan be provided and installed by the installing contractor, which should be properly sloped, installed according to code, and terminated in an area visible to the homeowner. Auxiliary pans provide extra protection to the area under the unit should the primary and secondary drain plug up and overflow.

WARNING

As expressed in our product warranty; ASPEN WILL NOT BE BILLED FOR ANY STRUCTURAL DAMAGES CAUSE BY FAILURE TO FOLLOW THIS INSTALLATION REQUIREMENT.

CAUTION

Drain lines from the auxiliary drain pan should NOT be connected to the primary drain line of the coil.

WARNING

Do NOT install coils with standard temperature drain pan with oil furnaces or applications where temperature of the drain pan might exceed 290 °F. A high-temp plastic or metal pan should be installed.

Install coils with the drain pan and/or casing on a flat, level surface. Slope the coil 1/4" towards the drain. Condensate lines must be installed in accordance with building codes. It is the contractor's responsibility to ensure proper condensate drainage at the time of the installation; Aspen bears no responsibility for damages caused by improper condensate management.

CAUTION

Some coils have primary and secondary drain ports on both sides of the pan to offer installation flexibility; ensure that all threaded plugs are installed tightly into unused drain pan ports. These may be hidden behind the coil casing access door. Failure to do so may result in property water damage; the contractor must ensure these plugs are present and tight.

The drain lines must be installed with 1/4" per foot pitch to provide free drainage. A condensate trap MUST be installed on the primary drain line to ensure proper drainage of the

condensate. The trap must be installed in the drain line below the bottom of the drain pan. Fig. 4-1 illustrates the typical drain trap installation. Prior to installation, ensure drain pan hole is not obstructed. Additionally, Aspen recommends the drain lines be insulated to prevent sweating and dripping.

Fig 4-1. Typical drain line trap setup

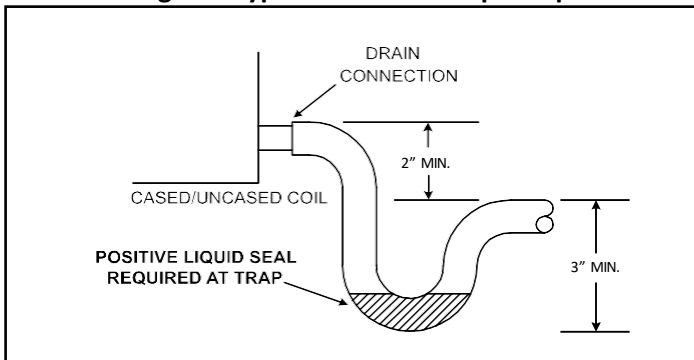

⚠ CAUTION

Use Teflon tape to connect the drain lines to the threads in the drain pan. DO NOT USE SOLVENT BASED PIPE DOPE. THIS WILL REDUCE THE LIFE OF THE PAN.

The drain pan has primary (white) and secondary (red) drain connections. If a secondary drain line is required, it should be run separately from the primary and should terminate in a highly visible location. Condensate disposal through the secondary drain line indicates that the primary drain line is plugged and needs cleaning. If a secondary drain line will not be provided, plug the secondary drain. Drain plugs are NOT to be reused without Teflon tape. Drain line connection should be finger tightened, then turned no more than one complete turn as needed to ensure a firm connection. DO NOT overtighten connection or damage may occur.

5. Coil Installation

⚠ WARNING

The coil is manufactured with dry nitrogen pre-charge. Release the pressure through the Schrader valve test port prior to installation. If holding pressure is not present, return coil to distributor for exchange.

Clean coil fins with degreasing agent or mild detergent and rinse fins clean prior to installation. Refer to section 10 for coil cleaning / maintenance guidance.

The refrigerant line sizes should be selected according to the recommendations of the outdoor unit manufacturer.

Care must be taken to ensure all connection joints are burr-free and clean. Failure to do so may increase chances of a leak. It is recommended to use a pipe cutter to remove the spun closed end of the suction line.

To reduce air leakage, rubber grommets may be present where the lines pass through the coil case. To avoid damage, remove grommets prior to brazing by sliding over the lines. Use a quenching cloth or allow the lines to cool before reinstalling the grommets.

Use of wet rags/quenching cloth is highly recommended to prevent weld-related damage to the casing and Schrader valve (if present).

⚠ CAUTION

Coil should be installed on the discharge side of the furnace.

⚠ CAUTION

Aspen coils may include a Schrader valve on the suction manifold. Ensure that the Schrader valve and valve core (where present) are protected from heat to prevent leakage.

⚠ WARNING

As mentioned elsewhere in this document, an application involving oil fired furnace must have a minimum of six inches of clearance between the discharge side of the furnace and the inlet of the coil.

5A. Dedicated Horizontal Drain Port Location

Condensate drain ports are located on both left and right sides. Refer to section 4 for condensate drain connections.

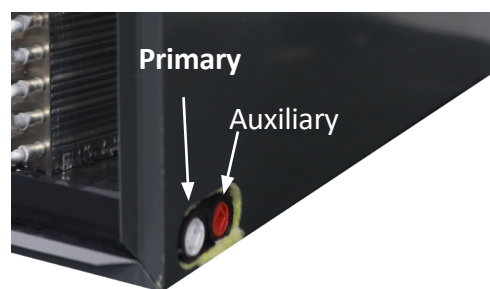

Fig 5A. Drain Port Location

5B. Dedicated Horizontal Orientation

⚠ CAUTION

Duct work must be installed in accordance with the local building codes. Aspen will not be liable for damages caused due by nonconformance to local building codes.

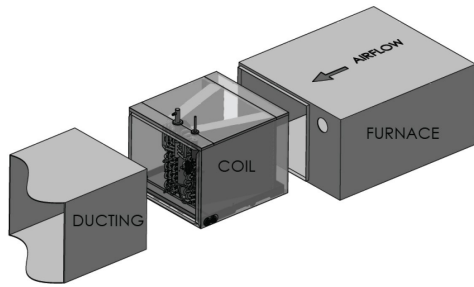

Fig 5B-1. Horizontal Left Application

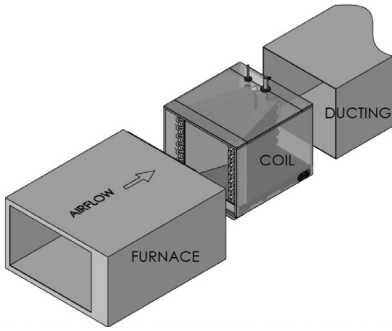

Fig 5B-2. Horizontal Right Application

Airflow enters through the inlet of the coil and exits at the outlet, entering the interior of the enclosure for routing to the attached ductwork.

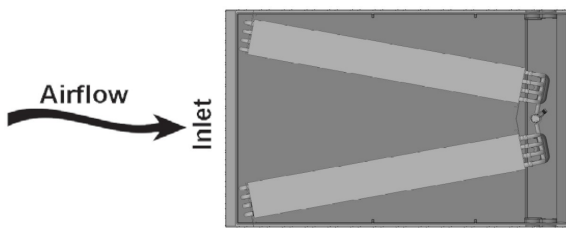

Fig 5B-3. Airflow Direction

5C. Mounting Dedicated Horizontal Coil to Furnace

1. Remove support bracket by loosening 2 screws on each side of the cabinet prior to installation and set aside. See Fig 5C-1
2. If applicable assemble the mounting support plate and support bracket. Mount the support bracket and plate assembly on the lower portion of the cabinet opening. The assembly will guide in mounting the coil cabinet towards the furnace. See Fig 5C-2

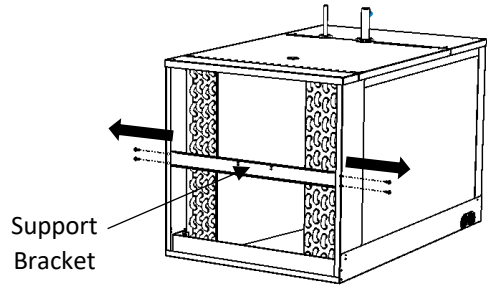

Fig 5C-1. Remove Support Bracket

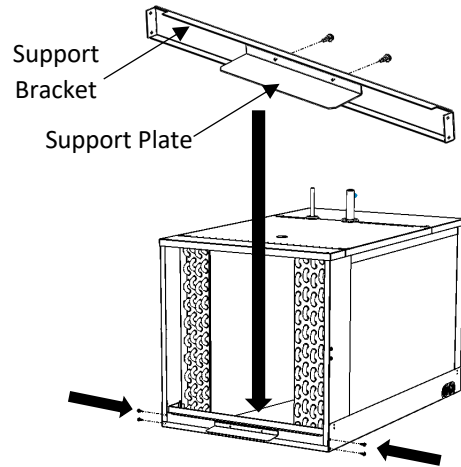

Fig 5C-2. Mount Support Bracket & Plate

3. For Style 1 (Coil cabinet is same height as furnace) – 3"x21" plate is provided to secure the mounting of furnace and coil cabinet. See Fig 5C-3A.

For Style 2 (Coil cabinet is taller than furnace) – Transition plate is provided to match height of furnace. See Fig 5C-3B.

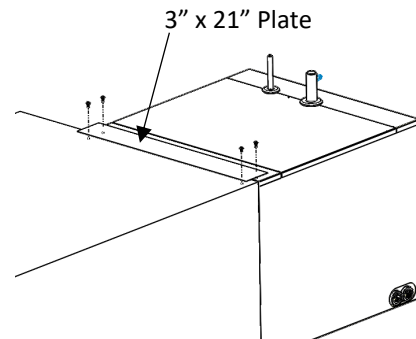
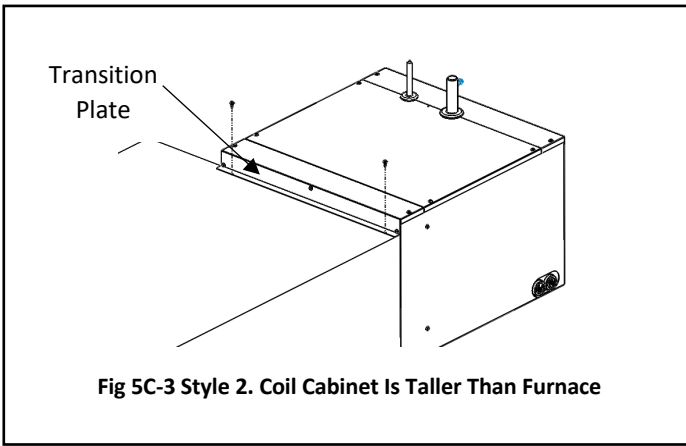

Fig 5C-3 Style1. Coil Cabinet Is Same Height As Furnace



⚠ CAUTION

Due to higher designed radiant heat, a six inches spacer (placed between the furnace exit and the inlet of the evaporator) should be installed when matching up an Aspen coil with an ultra-low NOx (ULN) furnace.

5E. Duct Attachment

To ensure optimal airflow, supply temperature, and airside pressure drop, connect ducts to the plenum board on the sides of the cabinet as close to the rear of the coil as possible.

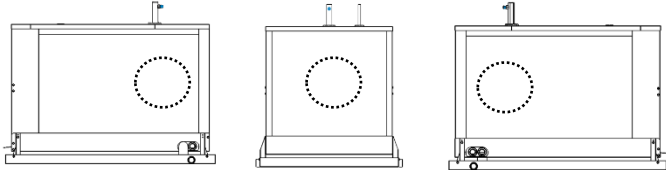

Round duct sizes that fit per cabinet height:

Cabinet Height (") (Ex. 14.5" = -145T)	8" DUCT	12" DUCT	14" DUCT
14.5/15	YES	NO	NO
17.5	YES	YES	NO
21	YES	YES	YES
24.5/25	YES	YES	YES

5D. Mounting Auxiliary Pan

- Using the 4-screw provided, Attached the four-mounting bracket on the auxiliary pan.

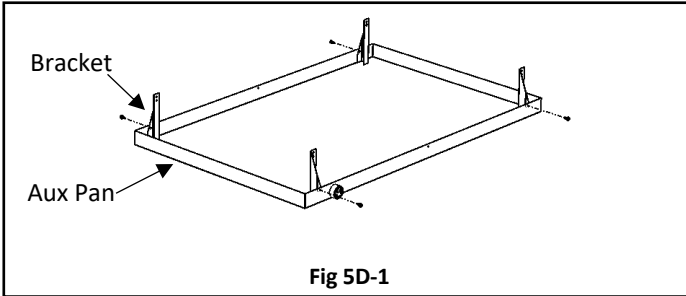

- Mount the auxiliary pan bracket in the coil cabinet as per desired position. 2 holes are provided on each 4 corners of the coil cabinet for adjustability purposes.

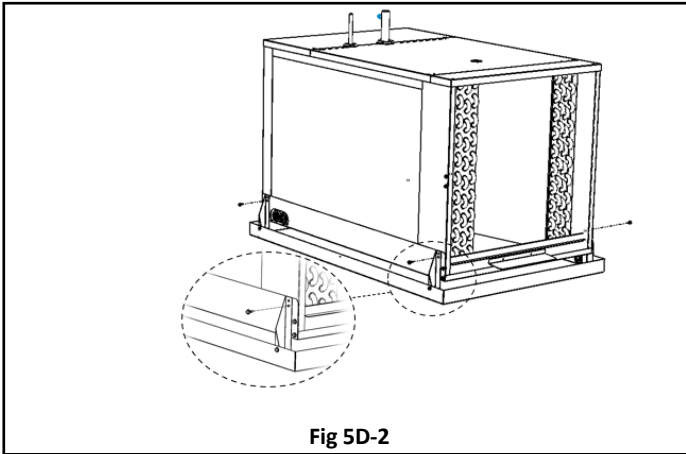

- Attached the auxiliary drain adaptor on the auxiliary drain port. Adaptor opening should be facing down.

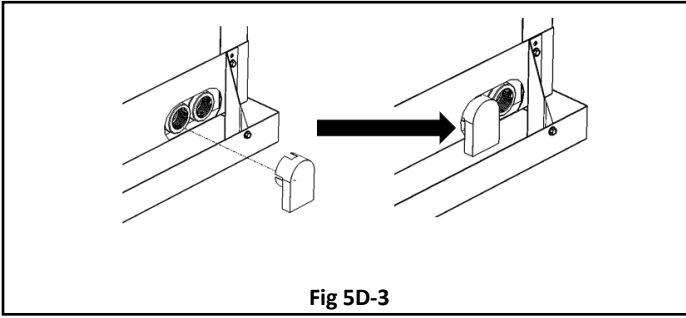

6. Refrigerant Line Connection

⚠ WARNING

The sensing bulb and TXV body **MUST** be protected from overheating during brazing. The sensing bulb and TXV body must be covered using a quench cloth or wet cloth when brazing. Pointing the brazing flame away from the valve and sensing bulb provide partial protection only.

⚠ CAUTION

Aspen coils may include a Schrader valve on the suction manifold. Ensure that the Schrader valve and valve core (where present) are protected from heat to prevent leakage.

- Release nitrogen holding charge by depressing the Schrader Valve at the suction line connection. If no gas releases from the coil, contact distributor regarding potential leak.

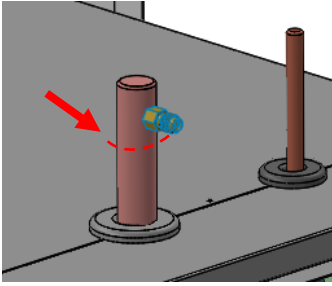
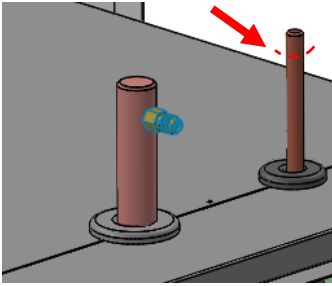
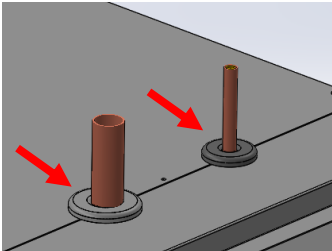
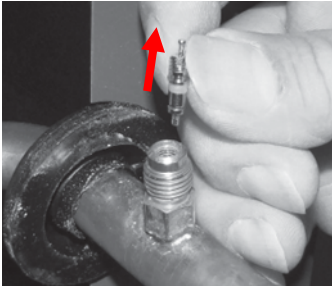
	<p>2. Ensure suction line connection joints are burr free and clean. Failure to do so may increase chances of a leak and introduce contaminants to the system. It is recommended to use a pipe cutter to remove the spun closed end and Schrader Valve fitting of the suction line.</p>
	<p>3. Use a tubing cutter to remove the spun end from the liquid line connection. Clean the burr from the cut tubing to reduce the chance of future leaks</p>
	<p>4. To avoid heat damage to grommets where present, remove these prior to brazing by sliding them over the refrigerant lines and out of the way.</p>
	<p>5. Check to determine if the evaporator coil has a Schrader fitting on the suction manifold. If yes, remove the valve core to prevent heat damage during brazing. Replace the valve core once the piping has cooled.</p>

6. Flow nitrogen through the piping when brazing
7. Braze both refrigerant line connections using proper brazing procedures.
8. When all line connections are brazed, perform a proper system evacuation procedure per the outdoor unit manufacturer instructions.
9. Seal the penetration openings where the line set piping enters the cabinet.

⚠ WARNING

Do not attempt to touch brazed joints while hot. Severe burns may result.

7. Metering Devices/Liquid Line Connection

Aspen coils are available with two kinds of metering devices a) Piston or b) TXV. The following instructions are separated into sections by metering device.

7A. Piston Coils

⚠ CAUTION

Use Piston sizes recommended by the outdoor unit manufacturer whenever possible. The piston should be sized according to the capacity of the outdoor unit.

⚠ WARNING

Failure to install the proper piston can lead to poor system performance and possible compressor damage.

NOTE: Photos are for basic illustration / reference purposes only. Actual equipment configuration may differ from that shown.

I. Piston Assembly

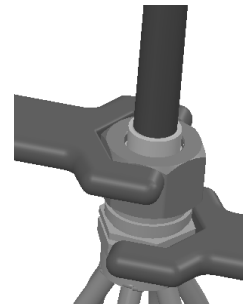

I-1. Disassemble flowrator body using two wrenches and unscrewing with a counterclockwise motion.

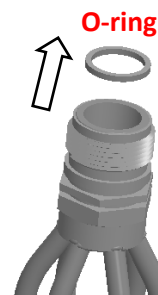

I-2. Replace the Teflon O-ring (located between the halves). Discard Schrader if present.

⚠ CAUTION

Be aware of the Teflon O-ring. Be sure to replace the O-ring to attain a proper seal. (The Teflon O-ring is located between the two halves of the flowrator)

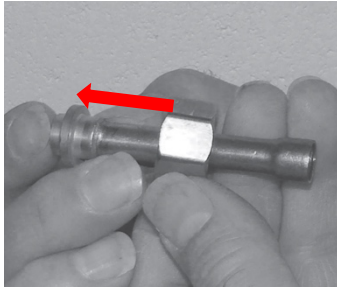

I-3. Slide the attachment nut onto the liquid line stub out.

I-4. Braze the stub-out portion to the liquid line and let cool.

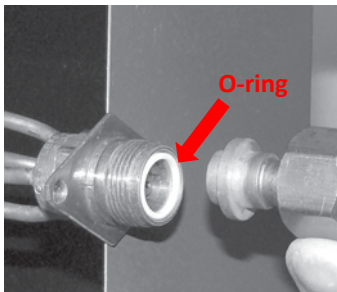

I-5. Taking care that the white Teflon O-ring is still in place inside the flowrator body, firmly seat the stub and screw the attachment nut to flowrator body.

I-6. Tighten nut using no more than 10 ft-lbs of torque. A flare nut open end wrench is recommended to evenly distribute the force across all six sides of the nut to ensure piston body is not deformed.

II. Piston Replacement

NOTE: Photos are for basic illustration/reference purposes only. Actual equipment configuration may differ from that shown.



Fig 7A-2. Piston Size Stamped

During some installations, a piston change may be required. If so, the installer **MUST** change the piston. Use piston sizes recommended by the outdoor unit manufacturer. If a sizing chart is not available, use the piston size chart provided below to size the required piston. The size of the piston is stamped on the piston body (Fig 7A-2).

Use the chart below when matching coil with an outdoor unit with a different nominal capacity than the coil.

Outdoor Unit Capacity	R22 Orifice Size	R410A Orifice Size
12,000	0.041	N/A
18,000	0.055	0.049
24,000	0.059	0.055
30,000	0.068	0.059
36,000	0.074	0.068
42,000	0.080	0.074
48,000	0.084	0.080
60,000	0.092	0.089

II-1. Evacuate the system as per manufacturer guidelines and recommendations.

II-2. Turn the 13/16" nut once to release any residual pressure in the coil.

	<p>II-3. After ensuring that the coil is free of any residual pressure, disassemble the flowrator body completely using two wrenches. Take great care not to distort the feeder tubes. The wrench used to clasp the nut should be turned in counterclockwise direction to unscrew the nut.</p>
	<p>II-4. Slide the 13/16" nut over the lineset and separate the two halves of the flowrator.</p>
	<p>II-5. Pull the piston out using a small wire or pick. Verify the piston size (size is typically stamped on the body of the piston - Fig 7A-2). If a different piston size is required by the outdoor unit manufacturer, replace the piston using the small wire provided with the piston kit.</p>

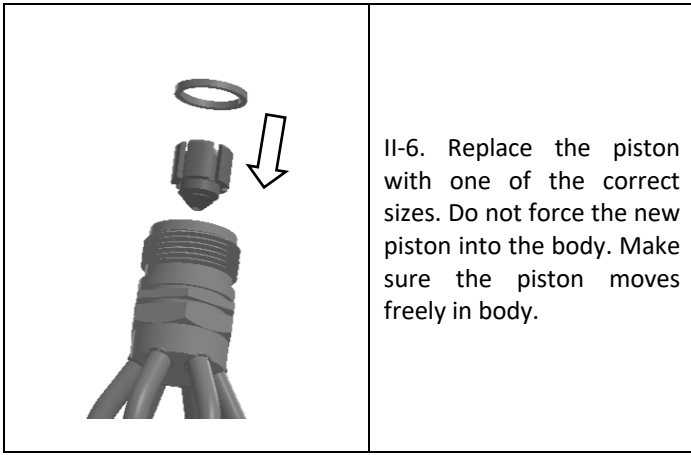

II-6. Replace the piston with one of the correct sizes. Do not force the new piston into the body. Make sure the piston moves freely in body.

CAUTION

Pay close attention to the piston orientation. The pointed end of the piston **MUST** go into the distributor body, towards the coil. Failure to ensure this orientation will cause the piston to be bypassed during operation which might damage the outdoor unit.

II-7. Assemble the two halves correctly and ensure that the Teflon O-ring is present between the two halves (See I-5). Slide the 13/16" nut onto the distributor body.

CAUTION

Be aware of the Teflon O-ring. Be sure to replace the O-ring to attain a proper seal. (The Teflon O-ring is located between the two halves of the flowrator).

II-8. Tighten the nut to a torque of approximately 10 ft-lbs. Do NOT overtighten the nut. Overtightening could crack the nut and/or impede the piston movement during operation.

II-9. If present, slide the rubber grommet back to position to prevent air leakage.

7B. TXV Coils

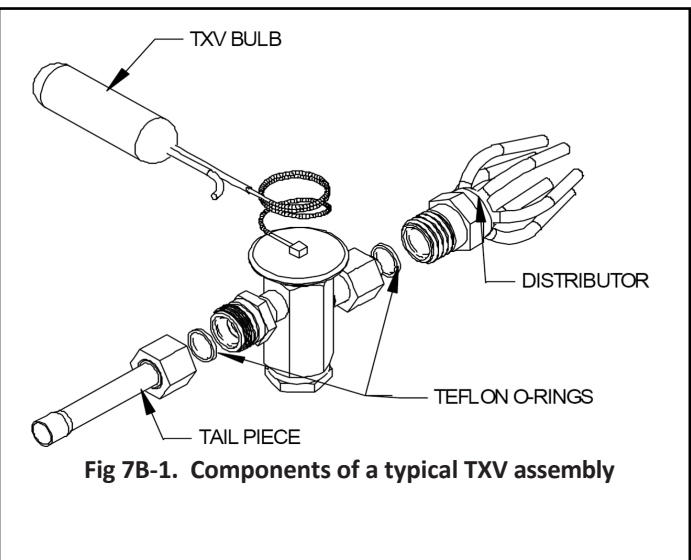

Fig 7B-1. Components of a typical TXV assembly

WARNING

The sensing bulb and TXV body **MUST** be protected from overheating during brazing. The sensing bulb and TXV body must be covered using a quench cloth or wet cloth when brazing. Pointing the brazing flame away from the valve and sensing bulb provide partial protection only.

CAUTION

Ensure that the TXV selected is compatible with the refrigerant used in the outdoor system (R22 or R410A). TXV caps are painted green for R22, pink for R410A, In absence of color, the caps will be marked with the compatible refrigerant.

CAUTION

The valves should be sized according to the capacity of the outdoor unit. Failure to install the right valve can lead to poor performance and possible compressor damage.

I. TXV Bulb Horizontal Mounting

The orientation and location of the TXV bulb has a major influence on the system performance.

CAUTION

Ensure that the TXV bulb is in direct contact with the suction/vapor line. Gap between the bulb and tube should be avoided. Failure to do so will impair the proper functioning of the TXV valve.

It is recommended that the TXV bulb be installed parallel to the ground (on a horizontal plane). The bulb position should be at 2 o'clock or 10 o'clock. Fig. 7B-2 shows the recommended position for the TXV bulb installation in the horizontal plane.

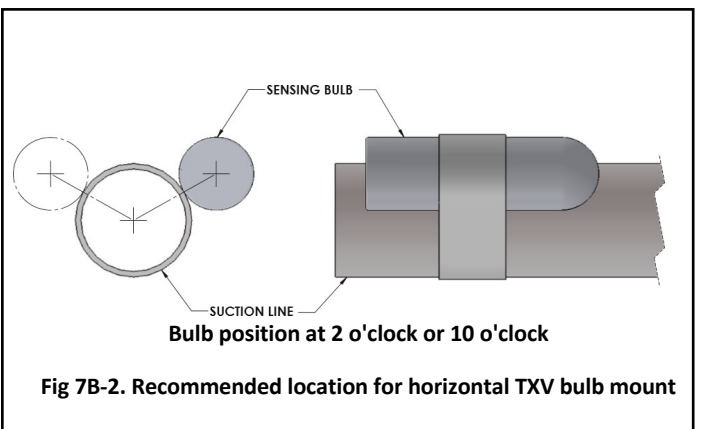

Fig 7B-2. Recommended location for horizontal TXV bulb mount

The TXV sensing bulb **SHOULD** be mounted on the suction line approximately 6" from the TXV or coil housing using the metal clamp provided. In order to obtain a good temperature reading

and correct superheat control, the TXV sensing bulb must conform to ALL of the following criteria:

1. The sensing bulb MUST be in direct and continuous contact with the suction line.
2. The sensing bulb should be mounted horizontally on the suction line.
3. The sensing bulb MUST be mounted at the 2 o'clock or 10 o'clock position on the circumference of the suction line.
4. The sensing bulb MUST be insulated from outside air.

A properly mounted sensing bulb will prevent false readings caused by liquid refrigerant that may have formed inside the suction/vapor line. Insulation will protect the sensing bulb from false readings due to contact with warm air.

II. TXV Bulb Vertical Mounting

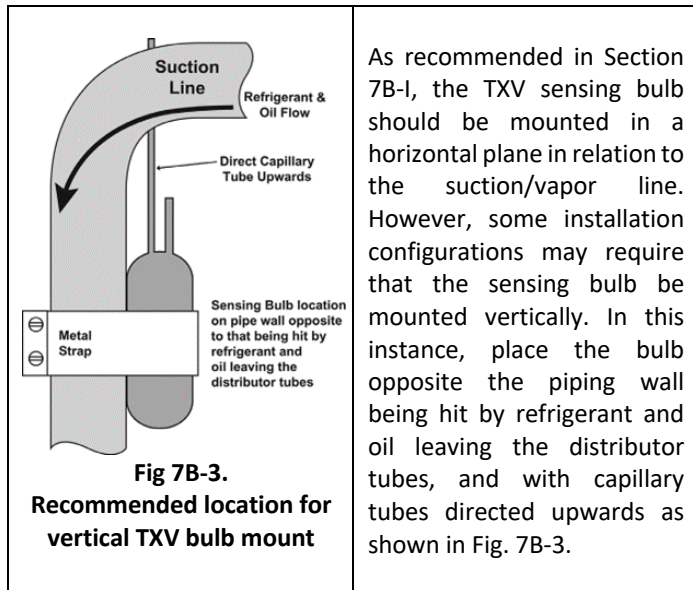

CAUTION

If the TXV sensing bulb is mounted vertically; the capillary MUST be directed upwards. The bulb must be mounted on the wall opposite to that being directly hit by the refrigerant and oil leaving the distributor tubes.

III. Field-Installed TXV Retrofit

Note: Photos are for basic illustration purposes only. Actual equipment configuration may differ from that shown.

WARNING

Do not attempt to touch brazed joints while hot. Severe burns may result.

When installing an expansion valve, it is not necessary to slide the coil out of the housing.

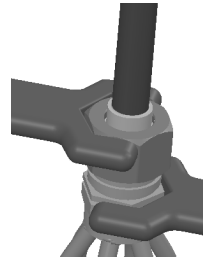

III-1. Disassemble the flowrator body using two wrenches. Unscrew the body with a counterclockwise motion.

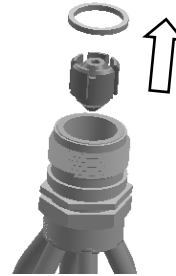

III-2. Remove the existing flowrator O-ring seal and piston using a small wire or pick.

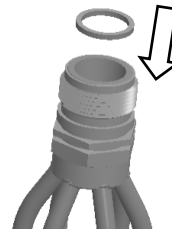

III-3. Replace a new Teflon O-ring seal in place (located between the halves).

III-4. Inspect the TXV box to confirm that the valve is compatible with the refrigerant in the system.

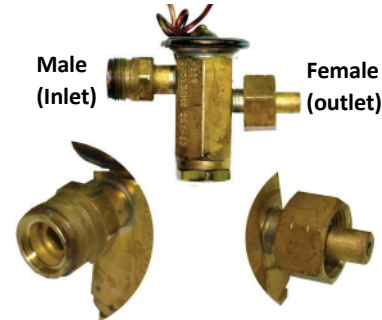

III-5. Remove the valve from the box and note the location of the inlet side (threaded male port) and the outlet side (female swivel nut port).

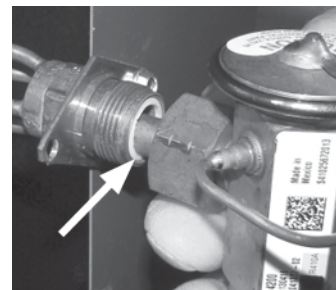

III-6. After ensuring that the Teflon O-ring seal is still in place inside the flowrator body, screw the female swivel nut onto the flowrator body.

III-7. Slide attachment the nut onto the liquid line stub out (See 7A, I-3)

III-8. Braze the stub-out portion to the liquid line and let cool.

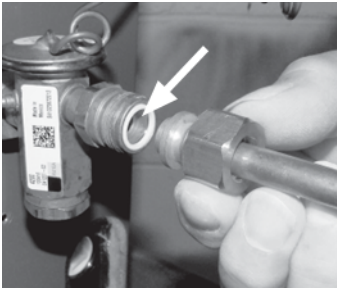

III-9. Remove the additional Teflon O-ring seal from the box and place on the shoulder just inside the TXV inlet port. Screw the nut attached to the stub-out portion of the flowrator body onto the inlet port of the TXV.

III-10. Tighten all connections taking care to use proper back up. Tighten the nut to a torque of approximately 10-30 ft-lbs.

III-11. Remove the valve identification sticker from the valve and place it adjacent to the Aspen model number on unit name plate.

III-12a. Some Aspen coils come with a Schrader valve on the suction line. **If a Schrader port is present:**

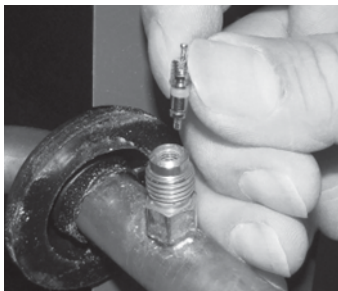

A. Remove the valve stem from the Schrader port mounted on the suction line.

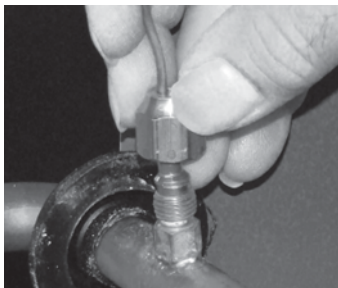

B. Screw flare nut on TXV equalization tube on to the Schrader valve stem.

III- 12b. In some cases, a suction line Schrader port may not be present. **If a Schrader port is NOT present:**



A. Install a field-supplied braze-on Schrader valve like that shown on the suction line near the intended sensing bulb mounting location. Follow valve manufacturer instructions and recommendations for installation.

B. Attach equalizer tube to valve as described in section III-12a above.

⚠ CAUTION

When handling or manipulating the equalizer tube, take great care not to kink or make extreme bends in the tubing.

⚠ CAUTION

Using a non-bleed expansion valve may require the use of a hard-start kit. Follow the outdoor unit manufacturer's guidelines.

8. Leak Check

1. Following outdoor unit manufacturer instructions and recommendations, charge the system with dry nitrogen to a maximum pressure of 150 PSIG.
2. Check all brazed and screw-on line connections by applying a soap solution to the joint. or other appropriate leak detection solution to the joint.

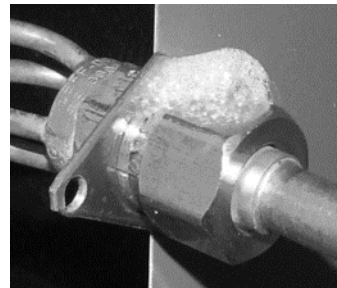

3. If any leaks are discovered, relieve system pressure and repair leaks. Repeat steps 1-3.
4. With no leaks or weak connections present, evacuate the system and charge as per the outdoor unit manufacturer instructions and specifications.

9. System Charging

⚠ CAUTION

Check all brazed and screw-on line connections by applying a soap solution or other appropriate leak detection solution to the joint.

⚠ CAUTION

Refer to outdoor unit manufacturer charging guidelines and recommendations. The recommendations given below are general in nature and are NOT to supersede outdoor unit manufacturer specifications.

Piston coil:

Add refrigerant until the superheat measured at the outdoor unit suction/vapor line matches the superheat from the chart below.

Outdoor Temp	Superheat		
	°F D.B.	Min	Nom
65	30	35	40
70	26	30	34
75	21	25	29
80	17	20	23
85	12	15	18
90	8	10	12
95	4	5	7
100			

TXV Coils:

If the unit is equipped with a **fixed TXV**, add refrigerant until the subcooling measures at the outdoor unit liquid line matches the subcooling recommendations of the outdoor manufacturer. If the charge is unavailable charge the unit to a subcooling value of 8°F +/- 1°F.

If the unit is equipped with an **adjustable TXV**, add refrigerant until the subcooling measures at the outdoor unit liquid line matches the subcooling recommendations of the outdoor manufacturer. If the charge is unavailable, charge the unit to a subcooling value of 8°F +/- 1°F.

NOTICE

When adjusting the TXV, the valve stem or adjusting screw should not be adjusted more than a ¼ turn at a time. To adjust superheat, turn the valve stem clockwise to increase and counterclockwise to decrease.

1. If subcooling and superheat are low, adjust TXV to 8°F +/- 1°F superheat, then check subcooling.
2. If subcooling is low and superheat is high, add charge to raise subcooling to 8°F +/- 1°F then check superheat.
3. If subcooling and superheat are high, adjust TXV valve to 8°F +/- 1°F superheat, then check subcooling.
4. If subcooling is high and superheat is low, adjust TXV valve to 8°F +/- 1°F superheat and remove charge to lower the subcooling to 8°F +/- 1°F.

The TXV should NOT be adjusted at light load / ambient conditions of 60°F or below.

10. Coil Cleaning Instructions

1. Aspen horizontal cased coils are equipped with three-piece access panel. To access the coil for cleaning and maintenance use the middle access panel. See figure 10-A and 10-B on how to properly remove and install the middle access panel.

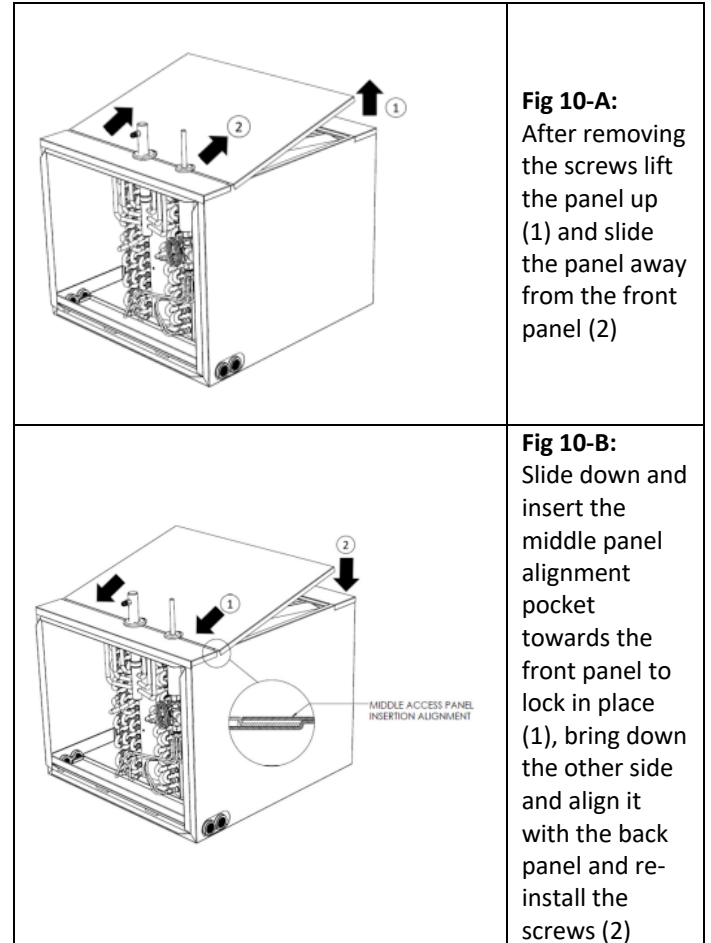

2. For both copper and aluminum tube coils, it is recommended to flush with the coil with water. There are coil cleaners that are available that contain corrosive chemicals, such as, but not limited to, chlorine and hydroxide, that are not approved for use on Aspen copper and aluminum tube coils.

DRAIN PAN TEMPERATURE TABLE	
DRAIN PAN TYPE	TEMP LIMITS
Plastic - Standard	290°
Plastic - High Temp	425°
Metal - High Temp	600°



373 Atascocita Rd.
Humble, TX 77396
Phone: 281.441.6500
Toll Free: 800.423.9007
Fax: 281.441.6510
www.aspenmfg.com

Part No. IO-A111
Rev. 11-2023

© Copywrite 2023 Aspen Manufacturing. All Rights Reserved.