



PES SERIES

PRODUCT DIMENSIONS & SPECIFICATIONS

HIGH EFFICIENCY ECM UNCASED CEILING MOUNT ELECTRIC HEAT DX COOL AIR HANDLER

WARRANTY

ONE YEAR LIMITED
PARTS WARRANTY

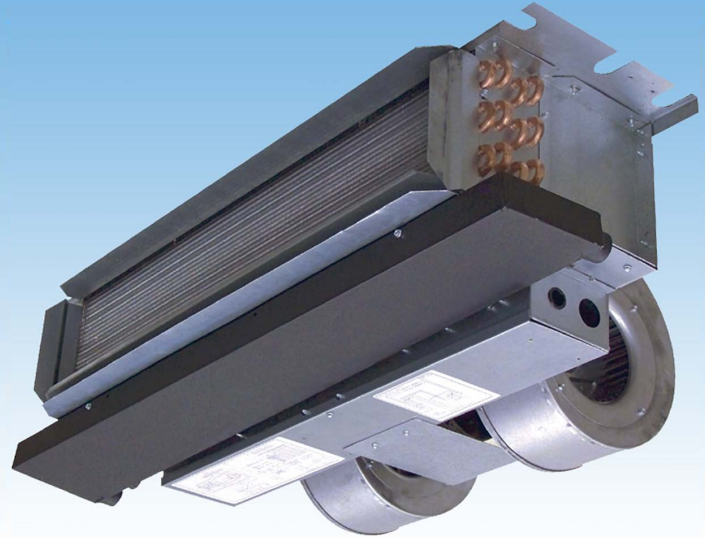

STANDARD FEATURES

■ APPLICATION VERSATILITY

Built in mounting tabs for ceiling or fur-down mounting. Louvered ceiling access panel has separate frame that attaches to ceiling joists. Solid access panel available for use with end return installations. Compatible with most brands of air conditioners or heat pumps.

■ MOTOR

Constant torque ECM allows motor speed control with embedded software. Motors are pre-programmed at the factory.

■ DIRECT EXPANSION COIL

High efficiency rifled copper tube/enhanced aluminum fins provide maximum heat transfer. All coils immersion tested at 500 psi then nitrogen pressurized and factory sealed for maximum reliability. Liquid-line Schrader allows pre-installation pressure testing. Available with either orifice or TXV metering device factory installed. Field-installable bolt-on TXVs is also available. Primary & secondary condensate drain. All drain connections are 3/4" MPT. Powder-painted metal drain pan. Access door allows for coil cleaning. Certified for use with either R22 or R410A

■ ELECTRONIC CIRCUIT BOARD

Electronic circuit board provides 30 secs ON/OFF blower time delay extracting more heat/cool from the coil. Automotive-style pull fuse protection on the circuit board to provide low voltage and transformer protection.

■ ELECTRIC HEAT KITS

Heat kits available in 3, 5, 6, 8 & 10 KW. Models with electric heat include sequencers and temperature limit switches for safe, efficient operation. Heat elements are replaceable without removing blowers. Easily accessible controls for quick service. Disconnect does not protrude through the wall panel.

■ LOW LEAKAGE

Less than 2% air leakage from cabinet when installed in enclosure and tested in accordance with ASHRAE 193. Unit must be installed in accordance with installation instructions. Sturdy, fully insulated galvanized enclosure with ducted return available as option.



**MANUFACTURED
IN THE USA**

OPTIONS
SEE OPTIONS MENU

WWW.AspenMFG.com

Last Revised: 06/24/21 | © 2021 Aspen Manufacturing

Representative image only. Some models may vary in appearance. Due to continuous product improvement, specifications are subject to change without notice.

Heating and Cooling Performance and Electrical Data										
Model	Heat Kit	Nominal Cooling (BTUS)	Performance Data				Electrical Data			
			Heating kW		Heating kBtu/h		Minimum Circuit Ampacity (MCA)		Max Breaker or Fuse Size	
			208V	240V	208V	240V	208V	240V	208V	240V
PES23	HTS00	18,000	0.0	0.0	0.0	0.0	5.0	5.0	15.0	15.0
	HTS03		2.3	3.0	7.8	10.2	18.5	20.6	20.0	25.0
	HTS05		3.7	4.8	12.6	16.4	26.6	30.0	30.0	30.0
	HTS06		4.6	6.0	15.7	20.5	32.0	36.3	35.0	40.0
	HTS08		6.1	8.0	20.8	27.3	41.1	46.7	45.0	50.0
	HTS10		7.4	9.6	25.3	32.8	48.3	55.0	50.0	60.0
PES26	HTS00	24,000	0	0.0	0.0	0.0	5.0	5.0	15.0	15.0
	HTS03		2.3	3.0	7.8	10.2	18.5	20.6	20.0	25.0
	HTS05		3.7	4.8	12.6	16.4	26.6	30.0	30.0	30.0
	HTS06		4.6	6.0	15.7	20.5	32.0	36.3	35.0	40.0
	HTS08		6.1	8.0	20.8	27.3	41.1	46.7	45.0	50.0
	HTS10		7.4	9.6	25.3	32.8	48.3	55.0	50.0	60.0
PES27	HTS00	18,000	0	0.0	0.0	0.0	5.0	5.0	15.0	15.0
	HTS03		2.3	3.0	7.8	10.2	18.5	20.6	20.0	25.0
	HTS05		3.7	4.8	12.6	16.4	26.6	30.0	30.0	30.0
	HTS06		4.6	6.0	15.7	20.5	32.0	36.3	35.0	40.0
	HTS08		6.1	8.0	20.8	27.3	41.1	46.7	45.0	50.0
	HTS10		7.4	9.6	25.3	32.8	48.3	55.0	50.0	60.0
PES28	HTS00	24,000	0	0.0	0.0	0.0	5.0	5.0	15.0	15.0
	HTS03		2.3	3.0	7.8	10.2	18.5	20.6	20.0	25.0
	HTS05		3.7	4.8	12.6	16.4	26.6	30.0	30.0	30.0
	HTS06		4.6	6.0	15.7	20.5	32.0	36.3	35.0	40.0
	HTS08		6.1	8.0	20.8	27.3	41.1	46.7	45.0	50.0
	HTS10		7.4	9.6	25.3	32.8	48.3	55.0	50.0	60.0
PES29	HTS00	30,000	0	0.0	0.0	0.0	5.0	5.0	15.0	15.0
	HTS03		2.3	3.0	7.8	10.2	18.5	20.6	20.0	25.0
	HTS05		3.7	4.8	12.6	16.4	26.6	30.0	30.0	30.0
	HTS06		4.6	6.0	15.7	20.5	32.0	36.3	35.0	40.0
	HTS08		6.1	8.0	20.8	27.3	41.1	46.7	45.0	50.0
	HTS10		7.4	9.6	25.3	32.8	48.3	55.0	50.0	60.0
PES33	HTS00	30,000	0	0.0	0.0	0.0	5.0	5.0	15.0	15.0
	HTS03		2.3	3.0	7.8	10.2	18.5	20.6	20.0	25.0
	HTS05		3.7	4.8	12.6	16.4	26.6	30.0	30.0	30.0
	HTS06		4.6	6.0	15.7	20.5	32.0	36.3	35.0	40.0
	HTS08		6.1	8.0	20.8	27.3	41.1	46.7	45.0	50.0
	HTS10		7.4	9.6	25.3	32.8	48.3	55.0	50.0	60.0
PES34	HTS00	36,000	0	0.0	0.0	0.0	5.0	5.0	15.0	15.0
	HTS03		2.3	3.0	7.8	10.2	18.5	20.6	20.0	25.0
	HTS05		3.7	4.8	12.6	16.4	26.6	30.0	30.0	30.0
	HTS06		4.6	6.0	15.7	20.5	32.0	36.3	35.0	40.0
	HTS08		6.1	8.0	20.8	27.3	41.1	46.7	45.0	50.0
	HTS10		7.4	9.6	25.3	32.8	48.3	55.0	50.0	60.0
PES35	HTS00	30,000	0	0.0	0.0	0.0	5.0	5.0	15.0	15.0
	HTS03		2.3	3.0	7.8	10.2	18.5	20.6	20.0	25.0
	HTS05		3.7	4.8	12.6	16.4	26.6	30.0	30.0	30.0
	HTS06		4.6	6.0	15.7	20.5	32.0	36.3	35.0	40.0
	HTS08		6.1	8.0	20.8	27.3	41.1	46.7	45.0	50.0
	HTS10		7.4	9.6	25.3	32.8	48.3	55.0	50.0	60.0
PES38	HTS00	36,000	0	0.0	0.0	0.0	5.0	5.0	15.0	15.0
	HTS03		2.3	3.0	7.8	10.2	18.5	20.6	20.0	25.0
	HTS05		3.7	4.8	12.6	16.4	26.6	30.0	30.0	30.0
	HTS06		4.6	6.0	15.7	20.5	32.0	36.3	35.0	40.0
	HTS08		6.1	8.0	20.8	27.3	41.1	46.7	45.0	50.0
	HTS10		7.4	9.6	25.3	32.8	48.3	55.0	50.0	60.0

BLOWER DATA

MODEL	SPEED TAP	MOTOR HP	CFM VS. STATIC PRESSURE							
			0.05	0.1	0.15	0.2	0.25	0.3	0.35	0.4
PES 23	T5	1/2	925	900	875	850	830	805	785	765
	T4		855	840	825	805	785	760	732.5	705
	T3		825	805	785	760	735	705	685	665
	T2		725	705	685	665	640	615	600	580
	T1		680	655	630	645	580	555	530	50
PES 26	T5		950	925	900	875	850	825	800	770
	T4		885	860	835	805	775	745	725	705
	T3		855	825	795	765	735	705	680	655
	T2		790	765	740	715	685	655	630	605
	T1		735	705	675	650	630	605	580	555
PES 27	T5		950	925	900	875	850	825	800	770
	T4		885	860	835	805	775	745	725	705
	T3		855	825	795	765	735	705	680	655
	T2		790	765	740	715	685	655	630	605
	T1		735	705	675	650	630	605	580	555
PES 28	T5		1205	1180	1155	1130	1100	1070	1025	1015
	T4		1145	1115	1085	1060	1040	1015	985	950
	T3		1045	1015	985	950	925	900	880	860
	T2		940	910	880	850	825	795	770	745
	T1		850	815	780	745	715	685	665	640
PES 29	T5		950	925	900	875	850	825	800	770
	T4		885	860	835	805	775	745	725	705
	T3		855	825	795	765	735	705	680	655
	T2		790	765	740	715	685	655	630	605
	T1		735	705	675	650	630	605	580	555
PES 33	T5		1205	1180	1155	1130	1100	1070	1025	1015
	T4		1145	1115	1085	1060	1040	1015	985	950
	T3		1045	1015	985	950	925	900	880	860
	T2	940	910	880	850	825	795	770	745	
	T1	850	815	780	745	715	685	665	640	
PES 34	T5	1220	1195	1170	1140	1115	1085	1065	1045	
	T4	1140	1115	1090	1060	1040	1015	990	965	
	T3	1025	1000	975	950	925	895	875	850	
	T2	950	920	890	860	835	805	775	745	
	T1	840	815	790	760	730	700	670	640	
PES 35	T5	1245	1220	1195	1165	1140	1115	1090	1060	
	T4	1160	1140	1120	1100	1080	1060	1030	1000	
	T3	1035	1010	985	965	940	910	885	860	
	T2	895	885	875	860	820	775	755	735	
	T1	840	815	970	765	735	705	685	665	
PES 38	T5	1335	1035	1285	1255	1225	1195	1160	1130	
	T4	1260	1230	1195	1165	1140	1115	1090	1070	
	T3	1160	1130	1110	1085	1065	1040	1020	1000	
	T2	1075	1045	1010	980	960	935	920	900	
	T1	965	935	910	885	850	810	795	775	

AIR HANDLER CHASSIS NOMENCLATURE

P	E	S	18	G	-001
AspenPRO Air Handler	Voltage E = 240V Constant Torque ECM	Configuration S = Uncased Ceiling Mount	Nominal Tonnage (KBTUH)	Metering Device 4 = R410A non-bleed A/C or H/P TXV 6 = R410A 20% bleed A/C or H/P TXV B = R22 20% bleed A/C or H/P TXV F = R22 Flo-rater G = R410A Flo-rater X = R22 non-bleed A/C or H/P TXV	Option Code

ELECTRIC HEAT KIT NOMENCLATURE

H	T	S	10
H = Fits PAS, PAT, PES, PET	T = Terminal Block	S = Small Cabinet (23 - 38)	Heat Strip 00 = NO Heat 03 = 3 KW 05 = 5 KW 06 = 6 KW 08 = 8 KW 10 = 10 KW

VERSATILITY

Equipped with hidden frame feature. Fastens to the outside wall surface and does not have to perfectly match the hole opening. Frame screws are not visible after installation. Available in either solid (S) or louvered (L) style.

MATERIALS

Galvanized steel construction with smooth powder paint finish.

FILTER

20" x 20" x 1" field supplied

WARRANTY

ONE YEAR LIMITED PARTS WARRANTY

CHASSIS DIMENSIONS

UNIT MODEL	A"	B"	C"	WEIGHT (LBS)	SKID QTY.
PES 23/26	37 1/4	34-5/8	30	135	8
PES 27	43 1/4	40-5/8	36	145	5
PES 28/29/34	49 1/4	46 5/8	42	155	4
PES 33/35/38	56 1/4	53 5/8	48	175	5

Copper stub out diameter: Suction: 3/4", Liquid: 3/8"

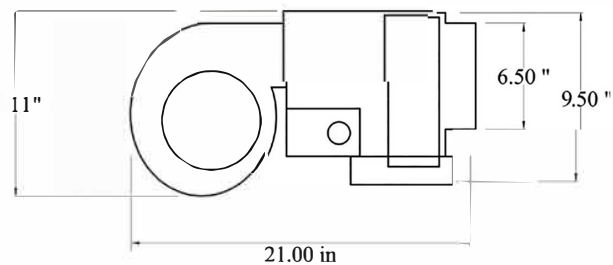
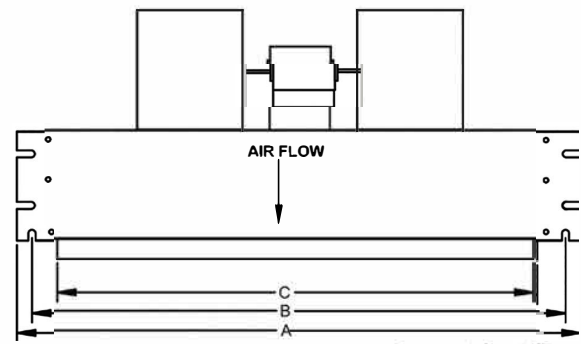

ACCESS DOOR DIMENSIONS

FOR USE WITH	PANEL MODEL	PBS ACCESS DOOR AND FRAME				FILTERS (QTY)
		A"	B"	C"	D"	
PES 23/26	GAD-1(S/L)	43-1/2	27-1/2	41-1/2	26	1
PES 27	GAD-5(S/L)	49-1/2	27-1/2	47-1/2	26	2
PES 28/29/34	GAD-2(S/L)	55-1/2	27-1/2	53-1/2	26	2
PES 33/35/38	GAD-6(S/L)	63-1/2	27-1/2	61-1/2	26	2

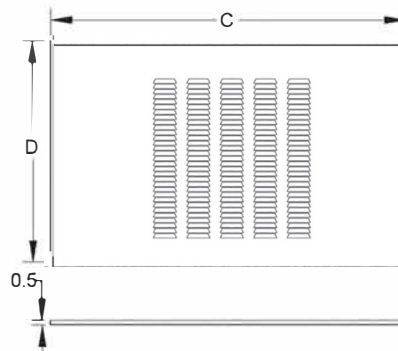
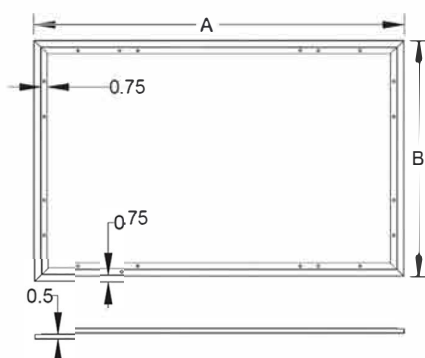

WARNING

CANCER AND REPRODUCTIVE HARM
WWW.P65WARNINGS.CA.GOV



Dependable, Lasting, Indoor-Comfort

373 Atascocita Rd | Humble, TX 77396
P: 800.423.9007 | F: 281.441.6510

www.AspenMFG.com



PET SERIES

PRODUCT DIMENSIONS & SPECIFICATIONS

HIGH EFFICIENCY ECM CASED CEILING MOUNT ELECTRIC HEAT DX COOL AIR HANDLER

WARRANTY

ONE YEAR LIMITED
PARTS WARRANTY



STANDARD FEATURES

■ APPLICATION VERSATILITY

Built in mounting tabs for ceiling or fur-down mounting. Louvered ceiling access panel has separate frame that attaches to ceiling joists. Solid access panel available for use with end return installations. Compatible with most brands of air conditioners or heat pumps.

■ MOTOR

Constant torque ECM allows motor speed control with embedded software. Motors are pre-programmed at the factory.

■ ELECTRONIC CIRCUIT BOARD

Electronic circuit board provides 30 secs ON/OFF blower time delay extracting more heat/cool from the coil.

■ ELECTRIC HEAT KITS

Heat kits available in 3, 5, 6, 8, & 10 KW. Models with electric heat include sequencers and temperature limit switches for safe, efficient operation. Easily accessible controls for quick service.

■ LOW LEAKAGE CABINET

Less than 2% air leakage from cabinet when tested in accordance with ASHRAE standard 193. Sturdy, fully insulated galvanized steel cabinet with knockout for duct return.

■ DIRECT EXPANSION COIL

High efficiency rifled copper tube/enhanced aluminum fins provide maximum heat transfer. All coils immersion tested at 500 psi then nitrogen pressurized and factory sealed for maximum reliability. Liquid-line Schrader allows pre-installation pressure testing. Available with either orifice or TXV metering device factory installed. Field-installable bolt-on TXVs is also available. Primary & secondary condensate drain. All drain connections are 3/4" NPT. Powder-painted metal drain pan. Access door allows for coil cleaning. Certified for use with either R22 or R410A.



MANUFACTURED
IN THE USA

OPTIONS

SEE OPTIONS MENU

www.AspenMFG.com

Last Revised: 06/24/21 | © 2021 Aspen Manufacturing

Representative image only. Some models may vary in appearance. Due to continuous product improvement, specifications are subject to change without notice.

Heating and Cooling Performance and Electrical Data										
Model	Heat Kit	Nominal Cooling (BTUS)	Performance Data				Electrical Data			
			Heating kW		Heating kBtu/h		Minimum Circuit Ampacity (MCA)		Max Breaker or Fuse Size	
			208V	240V	208V	240V	208V	240V	208V	240V
PET23	HTS00	18,000	0.0	0.0	0.0	0.0	5.0	5.0	15.0	15.0
	HTS03		2.3	3.0	7.8	10.2	18.5	20.6	20.0	20.0
	HTS05		3.7	4.8	12.6	16.4	26.6	30.0	30.0	30.0
	HTS06		4.6	6.0	15.7	20.5	32.0	36.3	35.0	40.0
	HTS08		6.1	8.0	20.8	27.3	41.1	46.7	45.0	50.0
	HTS10		7.4	9.6	25.3	32.8	48.3	55.0	50.0	60.0
PET26	HTS00	24,000	0	0.0	0.0	0.0	5.0	5.0	15.0	15.0
	HTS03		2.3	3.0	7.8	10.2	18.5	20.6	20.0	20.0
	HTS05		3.7	4.8	12.6	16.4	26.6	30.0	30.0	30.0
	HTS06		4.6	6.0	15.7	20.5	32.0	36.3	35.0	40.0
	HTS08		6.1	8.0	20.8	27.3	41.1	46.7	45.0	50.0
	HTS10		7.4	9.6	25.3	32.8	48.3	55.0	50.0	60.0
PET27	HTS00	18,000	0	0.0	0.0	0.0	5.0	5.0	15.0	15.0
	HTS03		2.3	3.0	7.8	10.2	18.5	20.6	20.0	20.0
	HTS05		3.7	4.8	12.6	16.4	26.6	30.0	30.0	30.0
	HTS06		4.6	6.0	15.7	20.5	32.0	36.3	35.0	40.0
	HTS08		6.1	8.0	20.8	27.3	41.1	46.7	45.0	50.0
	HTS10		7.4	9.6	25.3	32.8	48.3	55.0	50.0	60.0
PET28	HTS00	24,000	0	0.0	0.0	0.0	5.0	5.0	15.0	15.0
	HTS03		2.3	3.0	7.8	10.2	18.5	20.6	20.0	20.0
	HTS05		3.7	4.8	12.6	16.4	26.6	30.0	30.0	30.0
	HTS06		4.6	6.0	15.7	20.5	32.0	36.3	35.0	40.0
	HTS08		6.1	8.0	20.8	27.3	41.1	46.7	45.0	50.0
	HTS10		7.4	9.6	25.3	32.8	48.3	55.0	50.0	60.0
PET29	HTS00	30,000	0	0.0	0.0	0.0	5.0	5.0	15.0	15.0
	HTS03		2.3	3.0	7.8	10.2	18.5	20.6	20.0	20.0
	HTS05		3.7	4.8	12.6	16.4	26.6	30.0	30.0	30.0
	HTS06		4.6	6.0	15.7	20.5	32.0	36.3	35.0	40.0
	HTS08		6.1	8.0	20.8	27.3	41.1	46.7	45.0	50.0
	HTS10		7.4	9.6	25.3	32.8	48.3	55.0	50.0	60.0
PET33	HTS00	30,000	0	0.0	0.0	0.0	5.0	5.0	15.0	15.0
	HTS03		2.3	3.0	7.8	10.2	18.5	20.6	20.0	20.0
	HTS05		3.7	4.8	12.6	16.4	26.6	30.0	30.0	30.0
	HTS06		4.6	6.0	15.7	20.5	32.0	36.3	35.0	40.0
	HTS08		6.1	8.0	20.8	27.3	41.1	46.7	45.0	50.0
	HTS10		7.4	9.6	25.3	32.8	48.3	55.0	50.0	60.0
PET34	HTS00	36,000	0	0.0	0.0	0.0	5.0	5.0	15.0	15.0
	HTS03		2.3	3.0	7.8	10.2	18.5	20.6	20.0	20.0
	HTS05		3.7	4.8	12.6	16.4	26.6	30.0	30.0	30.0
	HTS06		4.6	6.0	15.7	20.5	32.0	36.3	35.0	40.0
	HTS08		6.1	8.0	20.8	27.3	41.1	46.7	45.0	50.0
	HTS10		7.4	9.6	25.3	32.8	48.3	55.0	50.0	60.0
PET35	HTS00	30,000	0	0.0	0.0	0.0	5.0	5.0	15.0	15.0
	HTS03		2.3	3.0	7.8	10.2	18.5	20.6	20.0	20.0
	HTS05		3.7	4.8	12.6	16.4	26.6	30.0	30.0	30.0
	HTS06		4.6	6.0	15.7	20.5	32.0	36.3	35.0	40.0
	HTS08		6.1	8.0	20.8	27.3	41.1	46.7	45.0	50.0
	HTS10		7.4	9.6	25.3	32.8	48.3	55.0	50.0	60.0
PET38	HTS00	36,000	0	0.0	0.0	0.0	5.0	5.0	15.0	15.0
	HTS03		2.3	3.0	7.8	10.2	18.5	20.6	20.0	20.0
	HTS05		3.7	4.8	12.6	16.4	26.6	30.0	30.0	30.0
	HTS06		4.6	6.0	15.7	20.5	32.0	36.3	35.0	40.0
	HTS08		6.1	8.0	20.8	27.3	41.1	46.7	45.0	50.0
	HTS10		7.4	9.6	25.3	32.8	48.3	55.0	50.0	60.0

BLOWER DATA

MODEL	SPEED TAP	MOTOR HP	BHP	CFM VS. STATIC PRESSURE									
				0.05	0.1	0.15	0.2	0.25	0.3	0.35	0.4	0.45	0.50
PET 23	T5	1/2	0.27	925	900	875	850	830	805	785	765	705	650
	T4		0.20	855	840	825	805	785	760	732.5	705	650	595
	T3		0.18	825	805	785	760	735	705	685	665	615	565
	T2		0.14	725	705	685	665	640	615	600	580	535	495
	T1		0.10	680	655	630	645	580	555	530	50	465	425
PET 26	T5		0.28	950	925	900	875	850	825	800	770	710	655
	T4		0.20	885	860	835	805	775	745	725	705	650	600
	T3		0.20	855	825	795	765	735	705	680	655	600	550
	T2		0.18	790	765	740	715	685	655	630	605	560	515
	T1		0.14	735	705	675	650	630	605	580	555	510	470
PET 27	T5		0.28	950	925	900	875	850	825	800	770	710	655
	T4		0.20	885	860	835	805	775	745	725	705	650	600
	T3		0.20	855	825	795	765	735	705	680	655	600	550
	T2		0.18	790	765	740	715	685	655	630	605	560	515
	T1		0.14	735	705	675	650	630	605	580	555	510	470
PET 28	T5		0.35	1205	1180	1155	1130	1100	1070	1025	1015	930	860
	T4		0.31	1145	1115	1085	1060	1040	1015	985	950	880	810
	T3		0.29	1045	1015	985	950	925	900	880	860	800	730
	T2		0.22	940	910	880	850	825	795	770	745	680	630
	T1		0.20	850	815	780	745	715	685	665	640	590	545
PET 29	T5	0.28	950	925	900	875	850	825	800	770	710	655	
	T4	0.20	885	860	835	805	775	745	725	705	650	600	
	T3	0.20	855	825	795	765	735	705	680	655	600	550	
	T2	0.18	790	765	740	715	685	655	630	605	560	515	
	T1	0.14	735	705	675	650	630	605	580	555	510	470	
PET 33	T5	0.35	1205	1180	1155	1130	1100	1070	1025	1015	930	860	
	T4	0.31	1145	1115	1085	1060	1040	1015	985	950	880	810	
	T3	0.29	1045	1015	985	950	925	900	880	860	800	730	
	T2	0.22	940	910	880	850	825	795	770	745	680	630	
	T1	0.20	850	815	780	745	715	685	665	640	590	545	
PET 34	T5	0.42	1220	1195	1170	1140	1115	1085	1065	1050	970	890	
	T4	0.33	1140	1115	1090	1060	1040	1015	990	965	894	820	
	T3	0.27	1025	1000	975	950	925	895	875	850	785	725	
	T2	0.25	950	920	890	860	835	805	775	745	690	630	
	T1	0.23	840	815	790	760	730	700	670	640	590	545	
PET 35	T5	0.45	1245	1220	1195	1165	1140	1115	1090	1060	980	900	
	T4	0.35	1160	1140	1120	1100	1080	1060	1030	1000	925	850	
	T3	0.31	1035	1010	985	965	940	910	885	860	800	730	
	T2	0.27	895	885	875	860	820	775	755	735	680	625	
	T1	0.25	840	815	970	765	735	705	685	665	615	565	
PET 38	T5	0.48	1335	1035	1285	1255	1225	1195	1160	1130	1045	960	
	T4	0.31	1260	1230	1195	1165	1140	1115	1090	1070	990	910	
	T3	0.29	1160	1130	1110	1085	1065	1040	1020	1000	925	850	
	T2	0.27	1075	1045	1010	980	960	935	920	900	830	765	
	T1	0.21	965	935	910	885	850	810	795	775	715	650	

VERSATILITY

Equipped with hidden frame feature. Fastens to the outside wall surface and does not have to perfectly match the hole opening. Frame screws are not visible after installation. Available in either solid (S) or louvered (L) style.

MATERIALS

Galvanized steel construction with smooth powder paint finish.

FILTER

20" x 20" x 1" field supplied.

WARRANTY

ONE YEAR LIMITED PARTS WARRANTY

ENCLOSURES DIMENSIONS

UNIT MODEL	A"	B"	C"	WEIGHT (LBS)	SKID QTY.
PET 23/26	40	30	30	135	5
PET 27	46	36	36	145	5
PET 28/29/34	52	42	42	155	5
PET 33/35/38	60	48	48	175	5

Copper stub out diameter: Suction: 3/4", Liquid: 3/8"

KNOCKOUT FOR DUCTED RETURN

(Ducted return requires remote filter grille (field supplied) and non-louvered panel)

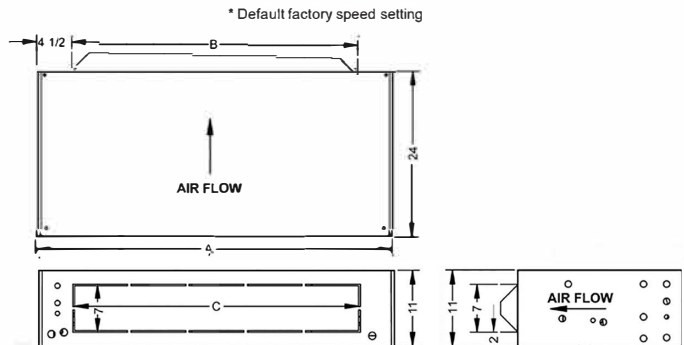

ACCESS DOOR DIMENSIONS

FOR USE WITH	PANEL MODEL	PBS ACCESS DOOR AND FRAME				FILTERS (QTY)
		A"	B"	C"	D"	
PET 23/26	GAD-1(S/L)	43-1/2	27-1/2	41-1/2	26	1
PET 27	GAD-5(S/L)	49-1/2	27-1/2	47-1/2	26	2
PET 28/29/34	GAD-2(S/L)	55-1/2	27-1/2	53-1/2	26	2
PET 33/35/38	GAD-6(S/L)	63-1/2	27-1/2	61-1/2	26	2

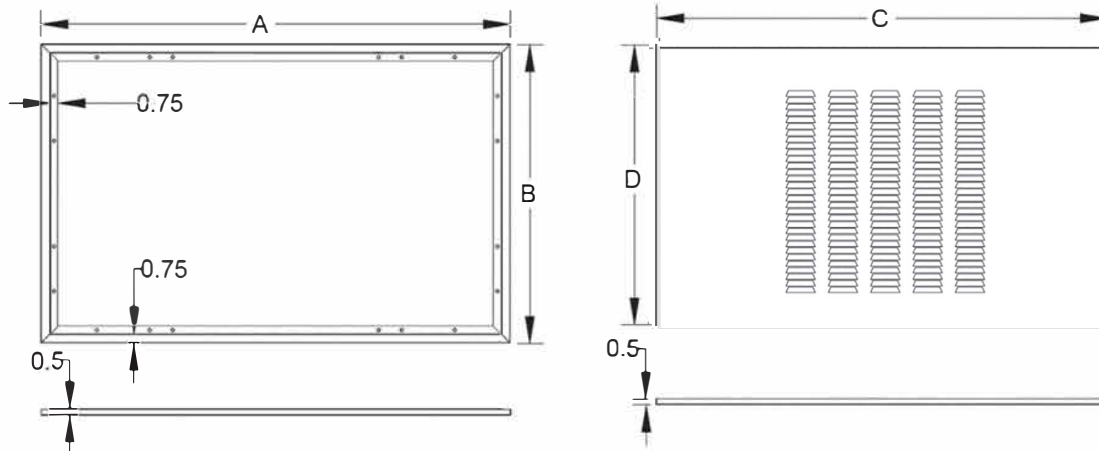

CAP KIT PART NUMBER

PART NUMBER	MODEL NUMBER	ENCLOSURE SIZE
CAP-1	PET 23/26	40"X24"X11"
CAP-2	PET 27	46"X24"X11"
CAP-3	PET 28/29/33/34	52"X24"X11"
CAP-4	PET 35/38	60"X24"X11"

Note: CAP kit is an insulated panel that covers the entire bottom opening and is utilized for optional ducted return configuration



Dependable, Lasting, Indoor-Comfort

373 Atascocita Rd | Humble, TX 77396
P: 800.423.9007 | F: 281.441.6510

www.AspenMFG.com



WARNING

CANCER AND REPRODUCTIVE HARM
WWW.P65WARNINGS.CA.GOV